

Rotary Coolant Adaptors : Drill Holder Type DIN 69871-A/ISO 7388/1

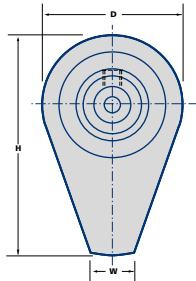
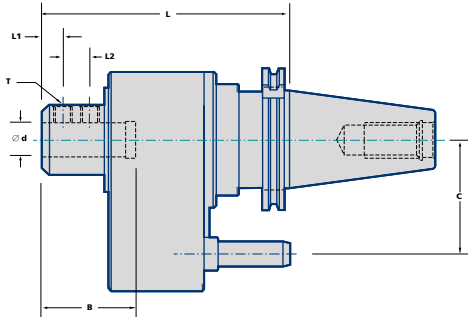

Available:
End Mill Sidelock Adaptors
ER, TG, DA Collet Chuck Systems

Taper	Ordering No.	Stock	d	L	H	D	W	h	B	L1	L2	T	Weight kg	Max rpm	
40	END MILL TYPE														
	DC40-R-EM16-150	•	16	150	130	86	26	65	50	13	-	M10	3.9	5,800	
	DC40-R-EM20-150	•	20	150	130	86	26	65	55	13	-	M10	3.9	5,800	
	DC40-R-EM25-150	•	25	150	130	86	26	65	65	15	-	M14	3.9	5,800	
	DC40-R-EM32-155	•	32	155	132,5	91	26	65	65	16	-	M14	4.6	5,000	
	DC40-R-EM40-170	•	40	170	140,5	106	30	65	80	16	19	M14	5.2	4,500	
	COLLET TYPE														
	DC40-R-DA188-165	•	3-20	165	130	86	26	65	55	-	-	-	3.9	5,800	
	DC40-R-TG100-175	•	6-25.5	175	132.5	91	26	65	64	-	-	-	4.6	5,000	
	DC40-R-ER32-160	○	3-20	160	130	86	26	65	55	-	-	-	3.9	5,800	
DC40-R-ER40-160	○	3-26	160	132.5	91	26	65	64	-	-	-	4.6	5,000		
50	END MILL TYPE														
	DC50-R-EM16-155	○	16	155	148	91	26	80	50	13	-	M10	7.7	5,000	
	DC50-R-EM20-155	•	20	155	148	91	26	80	55	13	-	M10	7.7	5,000	
	DC50-R-EM25-160	•	25	160	148	91	26	80	65	15	-	M14	7.7	5,000	
	DC50-R-EM32-175	•	32	175	155,5	106	30	80	65	16	-	M14	8.7	4,500	
	DC50-R-EM40-175	•	40	175	155,5	106	30	80	80	16	19	M14	8.7	4,500	
	DC50-R-EM50-180	•	50	180	166,5	121	30	80	80	16	19	M14	9.5	4,000	
	COLLET TYPE														
	DC50-R-TG100-185	•	6-25.5	185	155.5	106	30	80	70	-	-	-	8.7	4,500	
	DC50-R-ER32-160	○	3-20	160	148	91	26	80	50	-	-	-	7.7	5,000	
DC50-R-ER40-160	○	3-26	170	155.5	106	30	80	-	-	-	-	8.7	4,500		

• = Standard Product - Normally Ex Stock
○ = Standard Product - Availability on Request

Packing unit and ordering example: 1 piece DC40-R-EM16-150